



REFRIGERATION

SERVING THE FOOD INDUSTRY SINCE 1951

COUNTERTOP CURVED GLASS REFRIGERATED DISPLAY WITH DUAL ACCESS

Item: 31865
Model: RS-CN-0115-F

Item: 31866
Model: RS-CN-0155-F

Item: 31867
Model: RS-CN-0200-F



Model RS-CN-0155-F shown

ATTRACTIVELY DISPLAY FOOD MERCHANDISE AND INCREASE IMPULSE SALE

Omcan's Countertop Curved Glass Refrigerated Displays with dual access are perfect for supermarkets and sandwich shops. Features an attractive smooth finish, curved glass, and stainless steel body. Comes with digital temperature controller and automatic defrost system. The sliding doors in front and back allow for easy access to product while still maintaining the quality of the refrigerated merchandise.



WARRANTY
PARTS AND LABOR



SHIPPED ON PALLET

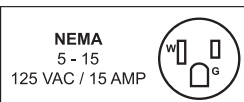

Authorized Dealer

REFRIGERATION

36-INCH CURVED GLASS REFRIGERATED DISPLAY
WITH DUAL ACCESS - 4 CU. FT. | RS-CN-0115-F



Item 31866 shown

FEATURES

- Sliding doors in front and back
- #304 Stainless Steel exterior and interior
- Forced air circulation system
- High quality digital temperature controller
- Middle or high back pressure hermetic compressor
- Automatic defrost system
- R134a Gas, Ozone friendly

TECHNICAL SPECIFICATIONS

ITEM NUMBER	31865
MODEL	RS-CN-0115-F
TEMPERATURE RANGE	2°C - 8°C / 35.6°F - 46.4°F
CAPACITY (L / CU. FT.)	115 L / 4 cu. ft.
POWER	0.420 kW
CURRENT	4.82A
REFRIGERANT	R134a, 185g
NUMBER OF SHELVES	2
ELECTRICAL	110V / 60Hz / 1Ph
INTERIOR DIMENSIONS (DWH)	15.75" x 35.5" x 14.5" 400.05 x 901.7 x 368.3 mm
DIMENSIONS (DWH)	21.25" x 35.5" x 31" 539.75 x 901.7 x 787.4 mm
PACKAGING DIMENSIONS	48" x 36" x 48"/ 1219 x 914 x 1219 mm
PACKAGING WEIGHT	343 lbs./155.58 kg.

TECHNICAL DRAWINGS AND DIMENSIONS

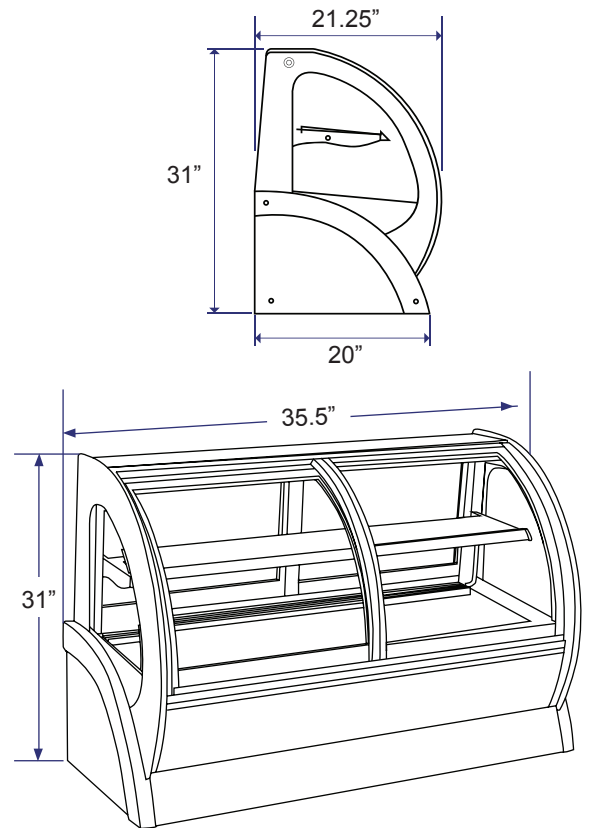

OMCAN INC.

Telephone: 1-800-465-0234
Fax: (905) 607-0234
Email: sales@omcan.com
Website: www.omcan.com



Follow us to keep up to date with the latest news and offers



REFRIGERATION

36-INCH CURVED GLASS REFRIGERATED DISPLAY
WITH DUAL ACCESS - 5.47 CU. FT. | RS-CN-0155-F



Item 31866 shown

FEATURES

- Sliding doors in front and back
- #304 Stainless Steel exterior and interior
- Forced air circulation system
- High quality digital temperature controller
- Middle or high back pressure hermetic compressor
- Automatic defrost system
- R134a Gas, Ozone friendly

TECHNICAL SPECIFICATIONS

ITEM NUMBER	31866
MODEL	RS-CN-0155-F
TEMPERATURE RANGE	2°C - 8°C / 35.6°F - 46.4°F
CAPACITY (L / CU. FT.)	155 L / 5.47 cu. ft.
POWER	0.453 kW
CURRENT	4.58A
REFRIGERANT	R134a, 270g
NUMBER OF SHELVES	2
ELECTRICAL	110V / 60Hz / 1Ph
INTERIOR DIMENSIONS (DWH)	15.75" x 47.25" x 14.5" 400.05 x 1200.15 x 368.3 mm
DIMENSIONS (DWH)	21.25" x 47.25" x 31" 539.75 x 1200.15 x 787.4 mm
PACKAGING DIMENSIONS	72" x 36" x 46" 1829 x 914 x 1168 mm
PACKAGING WEIGHT	404 lbs./ 183.25 kg

TECHNICAL DRAWINGS AND DIMENSIONS

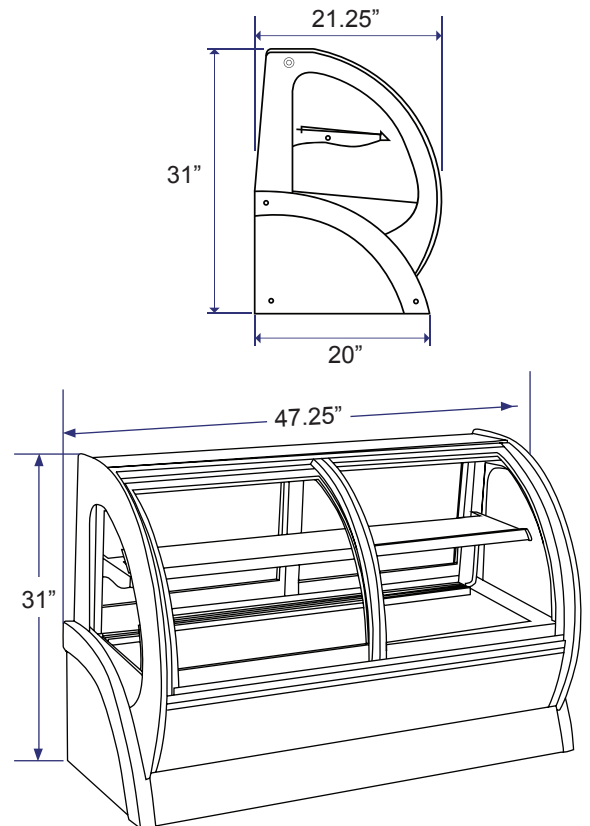

OMCAN INC.

Telephone: 1-800-465-0234
Fax: (905) 607-0234
Email: sales@omcan.com
Website: www.omcan.com



Follow us to keep up to date with the latest news and offers



REFRIGERATION

36-INCH CURVED GLASS REFRIGERATED DISPLAY
WITH DUAL ACCESS - 7 CU. FT. | RS-CN-0200-F



Item 31866 shown

FEATURES

- Sliding doors in front and back
- #304 Stainless Steel exterior and interior
- Forced air circulation system
- High quality digital temperature controller
- Middle or high back pressure hermetic compressor
- Automatic defrost system
- R134a Gas, Ozone friendly

TECHNICAL SPECIFICATIONS

ITEM NUMBER	31867
MODEL	RS-CN-0200-F
TEMPERATURE RANGE	2°C - 8°C / 35.6°F - 46.4°F
CAPACITY (L / CU. FT.)	200 L / 7 cu. ft.
POWER	0.479 kW
CURRENT	4.84A
REFRIGERANT	R134a, 300g
NUMBER OF SHELVES	2
ELECTRICAL	110V / 60Hz / 1Ph
INTERIOR DIMENSIONS (DWH)	15.75" x 59" x 14.5" 400.05 x 1498.6 x 368.3 mm
DIMENSIONS (DWH)	21.25" x 59" x 31" 539.75 x 1498.6 x 787.4 mm
PACKAGING DIMENSIONS	72" x 36" x 46"/ 1829 x 914 x 1168 mm
PACKAGING WEIGHT	444 lbs. / 201.39 kg.

TECHNICAL DRAWINGS AND DIMENSIONS

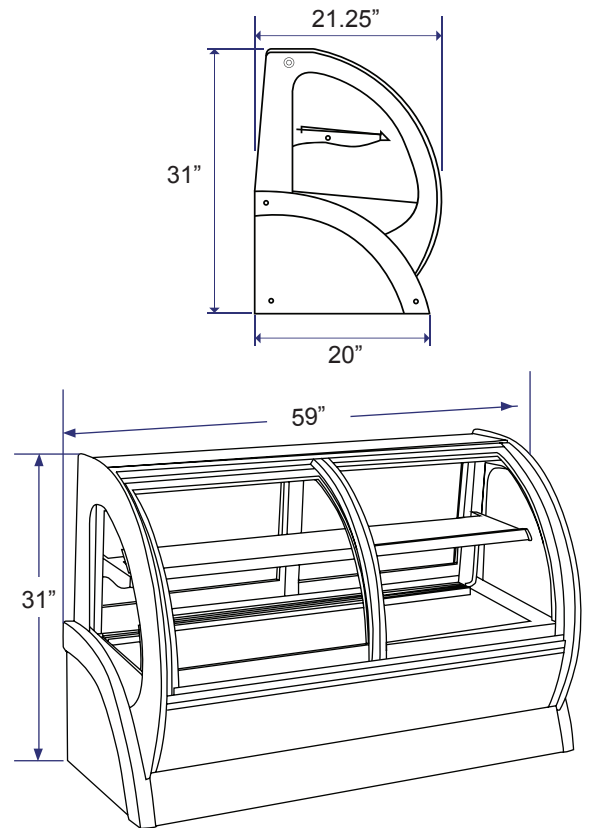

OMCAN INC.

Telephone: 1-800-465-0234
Fax: (905) 607-0234
Email: sales@omcan.com
Website: www.omcan.com



Follow us to keep up to date with the latest news and offers



2016.E.O.E